

# Ignitor Assembly for Wall-Fired Burners



R-V Industries, Inc.'s Ignitor Assembly for Wall-Fired Burners is designed for oil or gas pilots and can be equipped with an automated burner management controls package. It is also available with optional scanner and quick connections for the control cables.

Its modular design and mounting pipe allow for easy installation. The High Energy Electric Ignitor (HEEI) portion is featured on the reverse side.

## Specifications:

- **Enclosures:** Nema 12
- **Input Power:** 100 VAC, 60 Hz
- **Actuator Air:** 50 to 100 psig
- **Stroke Length:** 18" Standard for spark probe, 10" standard for pilot gun, others available
- **Limit Switches:** switching voltage 240 VAC/DC max, switching current 1.5 amp max, switching power 50W / 50 VA max
- **Solenoid Valves:** 120 VAC, 60 Hz, 0.4 amp inrush, 0.09 amp holding



Wall-Fired Ignitor shown with optional scanner and quick connections

## Features and Benefits:

- Spark probe and pilot gun positions are adjustable from the burner front and can be accomplished while the unit is on-line.
- Spark probe and pilot gun assemblies are mechanically quick-coupled for service and replacement.
- Rodless cylinders minimize space required at burner front.
- Proof of advanced and retracted positions provided by sealed proximity switch which can initiate a relay to energize the power pack.
- Independently adjustable advance and retract speed control.
- Actuator mounting brackets constructed of heat-insulating material.

# Retractable High Energy Electric Ignitor

R-V's Retractable High Energy Electric Ignitor (HEEI), can be used as a stand-alone NFPA Class 3 Special Ignitor for direct ignition of oil, natural gas, and propane. It can also be used in combination with an oil gun or gas gun as shown on the reverse side. The power pack includes a stainless steel jacketed high voltage cable with quick disconnect on the spark probe end.

## Features and Benefits:

- Spark probe position is adjustable from the burner front and can be accomplished while the unit is on-line.
- Spark probe assembly is electrically and mechanically quick-coupled for service and replacement.
- Power pack components are replaceable, eliminating the cost of complete power pack exchange.
- Proof of advanced position provided by a sealed proximity switch which can initiate a relay to energize the power pack.
- Rodless cylinder minimizes space required at burner front.
- Spark probe tip is easily replaced in minutes.
- Adjustable speed control.

## Retract Assembly Specifications:

- **Actuator Air:** 50 to 100 psig
- **Stroke Length:** 18" standard, others available
- **Solenoid Valve:** 120 VAC, 60 Hz, 20 watts, 135 VA inrush, 43 VA holding
- **Limit Switch:** 4 amps at 120 VAC, 3 amps at 24 VDC

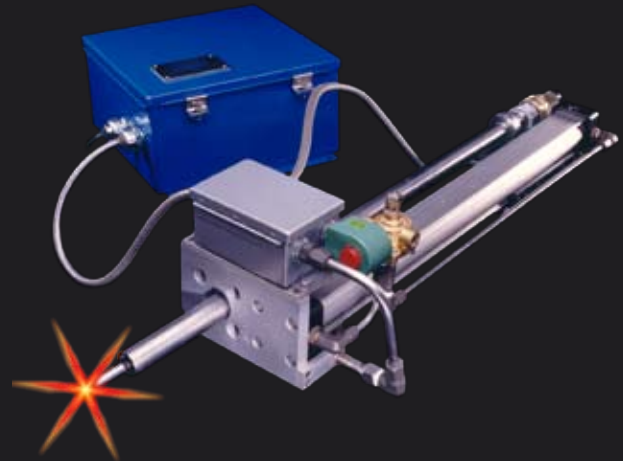

## Power Pack Specifications:

- **Enclosure:** Nema 4
- **Duty Cycle:** 1 minute on, 1 minute off; 10 cycles, 30 minutes off
- **Spark Probe Tip:** aircraft/surface gap, self cleaning design
- **Output Information:**
  - Rating: 16 Joules
  - Spark Rate: 5 - 10 times per second
  - Input Power: 110 VAC, 60 Hz

# Double Barrel Oil Guns

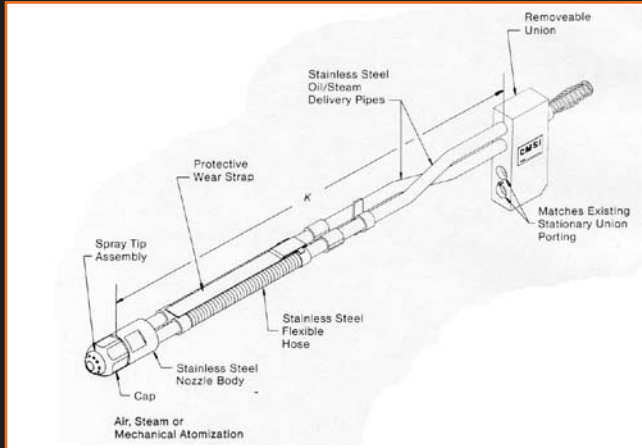

Double-barrel (DT-SS)  
oil gun for tilting applications

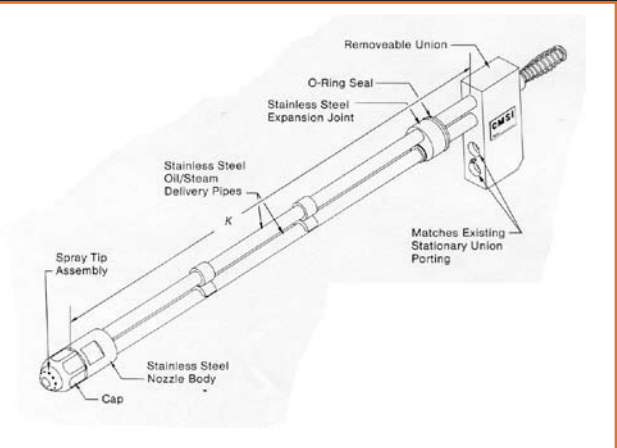

Double-barrel (DH-SS)  
oil gun for non-tilting applications

## Description:

The R-V double barrel oil gun utilizes two parallel stainless steel pipes for oil and steam (air) delivery (or oil return) to the mixing and spray tips. These smaller diameter pipes allow greater working pressure, greater safety ratio of allowable to actual working pressure, and result in a much lighter oil gun. Seal welding to both the removable union and the nozzle body eliminates threaded joints and the possibility of leaks as in concentric pipe designs. The flexible stainless steel hoses on the DT-SS gun are provided to accommodate the tilting capabilities. The hoses are protected from abrasion on top and bottom by stainless spring steel wear straps. Custom hoses are available for the DH-SS gun.

The removable union is machined from solid steel bar, eliminating the porosity and internal leakage possible with machined castings. The stainless steel nozzle body is constructed to match mixing plate, spray plate, and cap nuts currently in use.

## Benefits:

- Twin parallel pipes for oil and steam delivery minimize heat transfer and possible chilling of the steam line.
- Elimination of castings and large diameter piping reduces weight and handling.
- Smaller diameter piping allows higher working pressures.
- Small diameter flexible hose has shorter bend radius, increasing longevity.
- Stainless steel pipe, flexible hose and nozzle body construction produce extended life.
- Directly interchangeable with existing concentric style oil guns.
- Requires no modification of supply piping or stationary unions.

## Oil Gun Related Components

R-V also offers a variety of oil gun replacement components for OEM's such as ABB-CE, B&W, Peabody, Forney, and Todd.

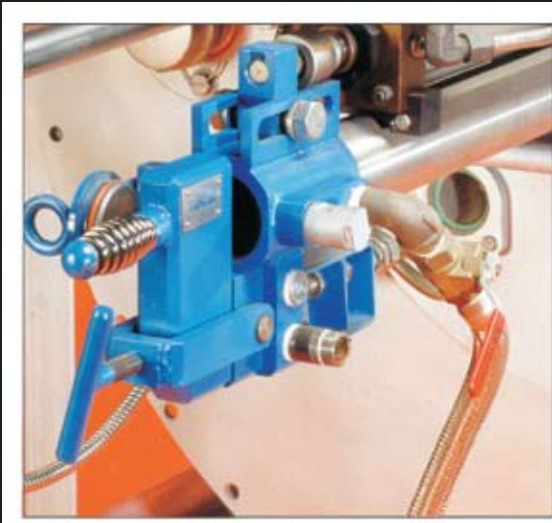

Stationary Union Assembly  
on end of Retractable Oil Gun



Removable Union

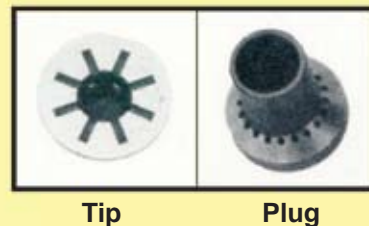
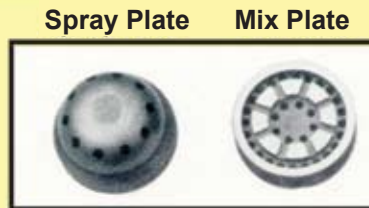
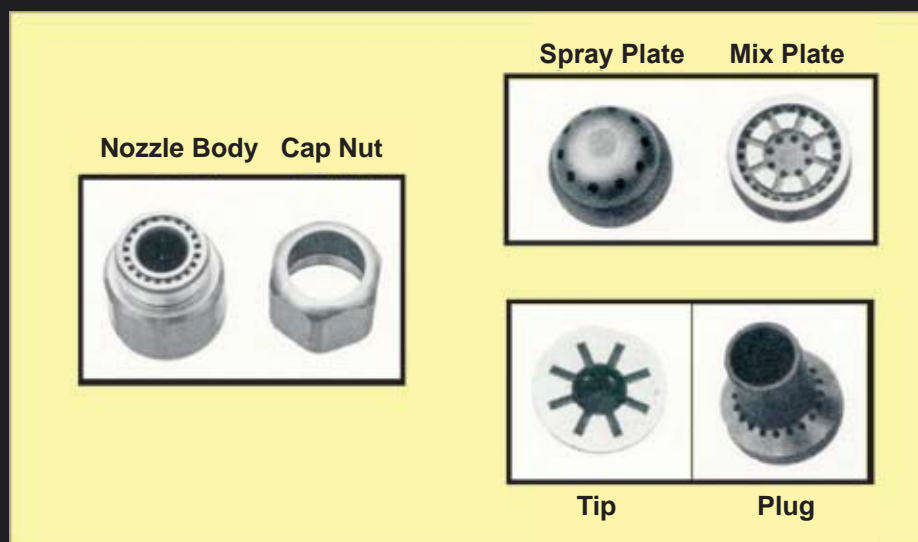

# Type RC Oil Gun Retract Mechanism



Reduce your maintenance dilemmas by installing our pneumatically operated mechanism which retracts the gun when the associated burner is no longer required for load. The Type RC retract fits all tangentially-fired furnaces. It is also interchangeable with all existing ABB-CE retracts and stationary oil guns, offering an inexpensive way to upgrade or improve your existing retracts. It has also been adapted to wall-fired oil burners such as the Peabody LEA burner.



## Advanced Technology

- Proof of position by sealed proximity switches.
- Heavy duty, yet light weight (unit weight = less than 200 lbs.).
- Anti-rotation device maintains vertical alignment of gun unions during clamping.
- Proximity gun engage switch.
- Individual speed control adjustment for both advance and retract prevents high speed slamming of actuator.
- One piece carbon graphite bearings, shrunk into a machined sleeve maintain alignment at windbox temperatures.

## Proven Reliability.

- Advanced performance.
- Quality components.
- Quality control supervision.
- 100+ test cycling.
- Major utility experience.

## Reduced Maintenance Time

Stationary guide pipe with a single cartridge bearing/seal assembly is accessible from the burner front and repairable while the boiler is online.

Seal tube vaned diffuser assembly remains in place using cartridge replacement.

Air and electrical connections are quick disconnects and change outs take only minutes.

Actuating cylinder, dual coil pilot solenoid valves and proof of position proximity switches are combined in a single, self-conditioned unit.

Eliminate gun seal replacement, burned or cracked tips, and total man hours through automation.

## Type RC Oil Gun Retract Mechanism

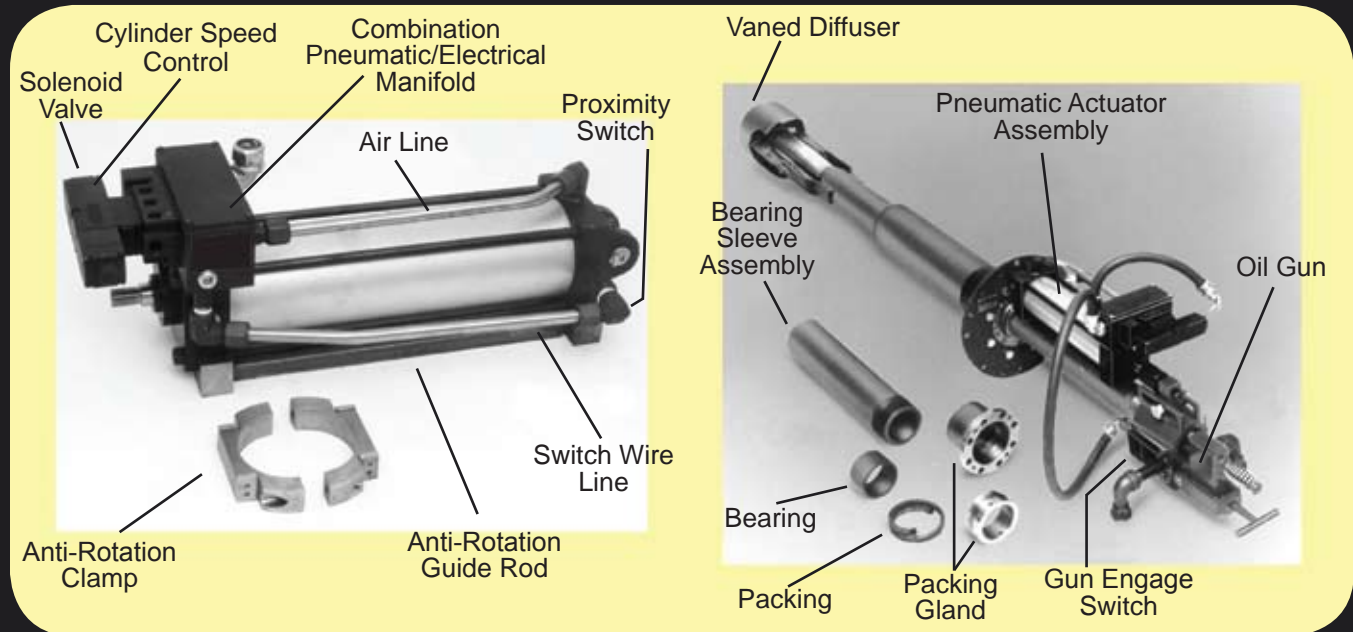

### Options:

- Mechanical latch to maintain the oil gun in firing position should loss of actuator air occur
- An aspirating air connection with oil gun latch for pressurized furnaces
- Gun engagement switches for dual firing
- Models available to fit every manufacturer's burner

### Guarantee:

- Type RC Oil Gun Retracts are manufactured to such high standards, we guarantee the bearing/seal cartridge to remain free of binding or freezing for 2 years
- The pneumatic actuator, including cylinder, pilot solenoid valves, and position sensors we guarantee for one year